



POTSDAM-INSTITUT FÜR
KLIMAFOLGENFORSCHUNG

Originally published as:

Deuber, O., Luderer, G., Edenhofer, O. (2013): Physico-economic evaluation of climate metrics: A conceptual framework. - *Environmental Science & Policy*, 29, 37-45

DOI: [10.1016/j.envsci.2013.01.018](https://doi.org/10.1016/j.envsci.2013.01.018)

Available at <http://www.sciencedirect.com>

© Elsevier

Deuber, Odette; Luderer, Gunnar^{*}; Edenhofer, Ottmar

Physico-Economic Evaluation of Climate Metrics: a Conceptual Framework

Affiliation of all authors: Potsdam Institute for Climate Impact Research, Postbox 601203, D - 14412 Potsdam

^{*} Corresponding author. luderer@pik-potsdam, phone: +49 331 2882671, fax: +49 331 288 2570

Abstract

The design of multi-gas mitigation policies requires methods for comparing the climate impact of different forcing agents—so-called metrics. A multitude of climate metrics has been presented in the literature. Key characteristics of any metric are (a) its impact function, i.e. its functional relationship to physical climate parameters, and (b) the weighting of impacts over time. In view of these characteristics, we present a physico-economic framework which allows classifying climate metrics from the literature in a straight-forward manner. From the economics perspective, the Global Damage Potential can be considered as a first-best benchmark metric since it ensures that the trade-off between different forcing agents is efficient. The conceptual framework based on economic principles shows that virtually all climate metrics including Global Warming Potential and Global Cost Potential can be constructed as variants of the Global Damage Potential. The framework facilitates a structured discussion on climate metrics since it reveals normative assumptions and simplifications that are implicit to the choice of a climate metric. The evaluation of commonly used metric approaches in terms of uncertainties reveals that the choice of metric is largely characterized by trade-offs between different kinds of uncertainties: explicit ones which are directly linked to operational feasibility and implicit structural ones which reflect the degree of policy relevance. Based on our findings, we suggest as an alternative option for policy applications to base exchange rates between forcing agents on an explicit analysis of the value-based, scientific and scenario uncertainties in the context of a physico-economic metric, rather than eliminating the relevant uncertainties by the choice of a physical metric.

Abbreviations

AM Absolute Metric

C Concentration

CO₂ Carbon Dioxide

D Economic Damage

δ -function Dirac Delta Function
 E Emission
 $EGWP$ Economic Global Warming Potential
 FEI Forcing Equivalent Index
 H Time Horizon
 GCP Global Cost Potential
 GDP Global Damage Potential
 GTP Global Temperature Potential
 GWP Global Warming Potential
 I Impact Function
 M Metric
 MAC Marginal Abatement Costs
 MDC Marginal Damage Costs
 PI Physical Impact Parameter
 PI_{thres} Physical Impact Threshold
 r Discount Rate
 ref Reference Concentration Pathway
 RF Radiative Forcing
 T Temperature
 t_x End Point
 $TEMP$ Temperature Proxy Index
 θ -function Unit Step Function
 W Weighting Function

1 Introduction

Cost-effective and comprehensive multi gas mitigation strategies as stipulated by the United Nation Framework Convention on Climate Change require climate change metrics. These represent methods for quantitatively comparing climate impacts of different radiatively active substances (e.g. Fuglestedt et al., 2010). A multitude of emission metrics have been presented in the literature. The choice of metric type is crucially important for the numeric values of greenhouse gas exchange rates (e.g. Boucher et al. 2012; Fuglestedt et al. 2010, see also Table 2). Identifying an appropriate metric approach for any mitigation strategy requires a clear definition and prioritization of policy

objectives. Climate metric design involves physical, economic and politico-economic aspects and requires a thorough interdisciplinary perspective and understanding (Plattner et al., 2009; Shine, 2009; Godal, 2003; O'Neill, 2003; Smith, 2003). The physical sciences are indispensable in metric design for quantifying how emissions affect climate. In virtually all metric applications (e.g. emissions trading, greenhouse gas inventories, life-cycle assessments), however, explicit or implicit assumptions about the marginal utility of emission abatement of different forcing agents are made, and thus metric design also has high relevance for the field of economics.

In the past, policymakers agreed on using a purely physical metric, the Global Warming Potential to set up the Kyoto Protocol (henceforth GWP(H)). The IPCC introduced this metric approach but also stressed that there is no unambiguous methodology for combining all relevant factors into a single metric approach (IPCC, 1990; Shine, 2009). The GWP(H) has been subject to criticism from both natural scientists and economists (O'Neill, 2000; Fuglestvedt et al., 2003 and 2010; Shine, 2009; Dorbian et al., 2011).

Most of the scientific climate metric literature assesses the rationale, the performance and limitation of certain metric types, such as physico-economic cost-benefit approaches (Eckhaus, 1992; Reilly and Richards, 1993; Schmalensee, 1993; Hammitt et al., 1996; Tol, 1999), cost-effectiveness approaches (Manne and Richels, 2001; Van Vuuren et al., 2006; Reilly and Richards, 1993) or physical metrics (Lashof and Ahuja, 1990; IPCC, 1990; Gillett and Matthews, 2010; Shine et al., 2005 and 2007; Tanaka et al., 2009; Peters et al., 2011). However, only few scholarly papers exist which consider metrics from a meta-perspective, including atmospheric and economic sciences. Fuglestvedt et al. (2003 and 2010) provide a detailed overview of climate metric design issues. Forster et al. (2007) present a general formulation of an emission metric, based on Kandlikar (1996). Finally, Tol et al. (2008) and Johansson (2011) highlight interrelations between metric approaches. A clearly structured discussion of climate metrics along the general formulation of an emission metric is lacking.

The design of climate metrics involves explicit and implicit assumptions on the functional relationship between climate impacts and physical climate change, and the aggregation of impacts occurring at different points in time. The objective of this article is to provide a physico-economic framework which classifies the Global Damage Potential (GDP), the Global Cost Potential (GCP) and currently discussed physical metrics in a straight-forward manner. The framework, based on impact and temporal weighting functions, provides a transparent classification scheme, thus revealing underlying implicit assumptions and value judgments. Our economic interpretation of physical metrics aims to foster trans-disciplinary exchange on this highly policy-relevant issue and to support decision-makers in identifying an appropriate metric, given normative judgments about the trade-off between policy targets.

Section 2 presents the general formulation of an emission metric. By linking it to the economic derivation of a climate metric, we develop a conceptual framework which classifies the variety of climate metrics from literature on the basis of economic rationales. The framework is established step by step in Section 3. Finally, Section 4 discusses

implications of alternative metrics regarding different types of uncertainties and draws some conclusions.

2 General formulation of an emission metric

The starting point of the conceptual framework is a generalized formulation of an emission metric as previously introduced by Kandlikar (1996) and Forster et al. (2007). It can be written as the integral over time of the incremental weighted impact incurred by a pulse emission of gas i .

$$AM_i = \int_0^{\infty} \frac{I(C_{(ref+\Delta E_i)}(t)) - I(C_{ref}(t))}{\Delta E_i} \cdot W(t) dt \quad (1)$$

where the impact function I describes the climate impact as a function of physical climate change C along a reference concentration pathway ref . W specifies the temporal weighting function. The corresponding metric value M_i ($M_i = AM_i / AM_{CO_2}$) refers to the impact of 1 kg of emission i (ΔE_i) normalized to the one of 1 kg reference gas, usually CO_2 (ΔE_{CO_2}). I and W are crucial determinants of the metric value M_i , and can be used to characterize alternative metrics.

2.1 Impact function

The impact function I relates the metric to a climate impact proxy in the chain of impacts, such as global mean radiative forcing (RF), the change in global mean temperature (ΔT) or economic damage (Hammit, 1999; Fuglestedt et al., 2003; van Vuuren et al., 2006; Plattner et al., 2009). In some cases, the rate of change of a climate impact parameter is also used as proxy. An ideal metric would consider the entire causal chain of impacts. Since, however, the last step, quantifying damages as a function of physical impact parameters, is subject to large scientific and value-based uncertainties (e.g. Forster et al., 2007; Wuebbles, 2010; Stern, 2007; Hanemann, 2010), it is common to make simplifying implicit assumptions about the interrelation between economic damage and physical impact and apply physical climate parameters as an impact proxy. Further, the assumed future concentration pathway is an important aspect of the impact function.

The impact function I in the generalized formulation of an emission metric (Eq. 1) refers to a pulse emission. Some approaches, however, calculate metric values based on sustained emissions or an emission scenario over an extended period of time (e.g. Shine et al. 2005; Deuber et al., 2012). Sustained emission metrics can be derived from pulse emission metrics through convolution, see e.g. Boucher (2012). For the sake of conceptual clarity, we focus our analysis on pulse emissions.

2.2 Weighting function

The weighting function W aggregates impacts occurring at different points in time. The following three variants are commonly used in climate metric design (Section 3.3, Fig. 1b)¹:

- (a) the exponential weighing function $W(t) = r \cdot e^{-rt}$, corresponding to the discount function commonly used in economics for aggregating monetary values over time with a discount rate r , given in % per year;
- (b) the unit step function (θ -function, e.g. Boas, 2006)

$$W(t) = \frac{1}{H} \theta(H - t) = \begin{cases} 1/H & \text{for } t \leq H \\ 0 & \text{for } t > H \end{cases} \quad (2)$$

which assigns equal weight to all impacts occurring over a finite time horizon H ; and

- (c) the Dirac Delta function (δ -function, e.g. Boas, 2006)

$$W(t) = \delta(t_x - t) = 0 \text{ for } t \neq t_x \text{ with } \int_{-\infty}^{\infty} F(t) \delta(t_x - t) dt = F(t_x) \quad (3)$$

which only evaluates the impacts at one discrete point in time t_x (end point weighting).

For each of these weighting functions, free parameters exist that determine the time scale of evaluation: the discount rate r (discounting), the time horizon H (θ -function) and the end point t_x (δ -function). Again, the choice of these time frame parameters involves normative decisions. In most metric approaches they are taken as constant. Some physical metrics exist, however, in which the time frame parameter is replaced by the distance between the point in time of emission release and a specific target year (e.g. Berntsen et al., 2010; Shine et al., 2007; Tanaka et al., 2009).

3 Characterizing climate metrics

In the following, we establish a conceptual framework by characterizing alternative metric choices based on the applied impact and weighting function. In Section 3.1 we demonstrate how the Global Damage Potential is derived from first economic principles. Other metrics can be interpreted as variants of this benchmark approach (Section 3.2). The synthesis provided in Section 3.3 reveals the implicit assumptions underlying the alternative approaches and highlights interrelations across the metric types.

¹ We normalized the weighting functions such that $\int_0^{\infty} W(t) dt = 1$.

3.1 The first-best approach: Global Damage Potential

The concept of marginal impacts from emission pulses, which serves as a basis for the definition of the absolute metric (Section 2), is grounded in the cost-benefit analysis, building on marginal climate change impacts and marginal costs of emission reductions. An economically optimal abatement strategy implies that the sum of mitigation and damage costs assumes a minimum. In our case of greenhouse gases with varying atmospheric lifetimes, this means that the discounted present value of marginal abatement costs (MAC) of an emission of agent i has to be equal to the marginal discounted present value of damage costs (MDC) of the same emission;

$$MAC_i = MDC_i \quad (4)$$

In the case of CO_2 , these MDC s are often referred to as the social costs of carbon and correspond to the optimal (Pigouvian) tax level (Pigou, 1932; Baumol, 1972; Nordhaus, 1991; Fankhauser, 1995).

In view of uncertainty about the MAC s, it is not possible for policymakers to define *ex ante* optimal abatement levels for each individual greenhouse gas. Instead, emissions can be regulated by introducing a cap for the total emissions and assigning an emission metric to each individual gas, thus letting the market decide how best to achieve the total emission constraint (“what flexibility”). An optimal climate metric is one that relates the marginal costs of emission control to the future stream of damages of climate change avoided by that emission reduction. In this case, the metric M_i of a pulse emission i equals its potential climate impact (also referred to as absolute metric AM_i) normalized to the impact incurred by a reference gas (usually carbon dioxide (CO_2 , AM_{CO_2}), see for a detailed mathematical framework Tol et al. (2008):

$$M_i^D = \frac{AM_i}{AM_{CO_2}} = \frac{MDC_i}{MDC_{CO_2}} = \frac{MAC_i}{MAC_{CO_2}} \quad (5)$$

By establishing a ratio of MDC s, the scaling factor from physical impact to economic costs including the related uncertainties cancels out; solely the functional form of the economic damage function remains relevant. The requirement in Eq. (5) that the metric be equal to the ratio of MAC s arises directly from the efficiency condition (Eq. 4).

The corresponding first-best metric approach from a socio-economic point of view is the Global Damage Potential (GDP, Eckhaus, 1992; Kandlikar, 1996; Tol, 1999). The GDP, also named Economic Damage Index (EDI) (Hammit et al., 1996), is based on the evaluation of the future stream of discounted economic damages:

$$GDP : M_i^D = \frac{\int_0^{\infty} \frac{\partial D}{\partial E_i} \cdot \Delta E_i \cdot e^{-rt} dt}{\int_0^{\infty} \frac{\partial D}{\partial E_{CO_2}} \cdot \Delta E_{CO_2} \cdot e^{-rt} dt} \quad (6)$$

Typically, exogenous scenario assumptions on future atmospheric background greenhouse gas concentrations are taken. Beyond predicting changes in physical parameters,

the fundamental challenge in GDP calculation consists of determining the functional form of the damage function, which relates economic damages to changes in physical impact parameters. In economic analysis of climate change it is most common to assume damage to be a convex function of ΔT (e.g. $D = \alpha \Delta T^n$, Nordhaus, 1991; Kandlikar, 1995; Tol, 1999; Nordhaus and Boyer, 2000; Stern, 2007) while some approaches (e.g. Hammitt, 1996; Tol, 2003) additionally consider potential discontinuities.

Even though in economic literature there is a rough conception of the functional interrelation between economic damage and physical climate impact parameter, it is very challenging to quantify damages. It is characterized by a high degree of scientific uncertainty since it requires a full representation of the relevant complex causal relationships, including a down-scaling of global changes to the regional and local level (Hanemann, 2010). On the other hand, valuing climate impacts is closely related to questions of irreversibility and inter- and intragenerational equity and requires value judgements, in particular with regards to the aggregation of impacts across regions and over time, as well as the treatment of non-market impacts (Tol, 2005). The economic evaluation of non-market goods such as ecosystem loss, climate amenity, health and higher mortality risks is strongly controversial (e.g. Stern, 2007).

In climate metric design, handling uncertainty with respect to the functional form of the economic damage function is the key motivation to refrain from the theoretically optimal cost-benefit approach. Specific assumptions are taken to simplify the case (“second best approaches”) (Tietenberg, 1992).

3.2 Classification of other metric approaches

There are two fundamentally different second-best approaches to avoid the uncertainty associated with the functional form of the economic damage: physical metrics use impact functions that are based on physical climate variables, whereas cost-effectiveness approaches calculate economically optimal exchange rates between greenhouse gases given a prescribed climate target. Both approaches are discussed in the following.

3.2.1 Physical metrics

Physical climate metrics avoid the perils of economic evaluation by choosing a physical impact proxy that is located further upstream in the chain of impacts (ΔT or RF), implicitly assuming linearity between economic damage and physical impact proxy. The uncertainty affecting metric calculation is thus reduced to uncertainties related to the physical processes of the climate system, e.g. the carbon cycle, atmospheric chemistry interactions and radiative effects (RF as proxy), as well as the climate sensitivity and the time scale of the climate response (ΔT as proxy) (Fuglestedt, 2003, 2010; Forster et al., 2007). Simplifications are achieved by assuming a specific background concentration pathway C_{ref} .

A multitude of temperature-based metrics are proposed in literature: They differ in their choice of W , time frame parameter and C_{ref} . The Global Temperature Change Potential applies the δ -function, referring either to a pulse or a sustained emission with a constant end point t_x ($t_x=const$) (GTP_p, GTP_s) (Shine et al., 2005), or to a pulse emission with a

time-dependent end point representing the distance between the time of emissions release t_0 and the time t_{tar} at which a specific climate target is expected to be reached ($t_x = t_x(t_0, t_{tar})$) ($GTP_p(t)$, Shine et al., 2007). The Mean Global Temperature Potential MGTP(H) (Gillett and Matthew, 2010), in contrast, applies the θ -function for weighting. The MGTP(H), GTP_p and $GTP_p(t)$ in their original versions assume constant atmospheric conditions ($C_{ref} = C_{ref}(t_0)$). However, the $GTP_p(t)$ refers indirectly to an exogenously determined emission scenario via the shortening of the time horizon over time ($t_x = t_x(t_0, t_{tar})$). It suggests itself that the exogenously determined scenario can also be used as \bar{C}_{ref} (e.g. Deuber et al., 2012).

RF-based metrics, such as the GWP(H), relate generally to a defined constant atmospheric state. The GWP(H) applies the θ -function and assumes constant atmospheric condition of the emission year ($C_{ref} = C_{ref}(t_0)$) (IPCC, 1990). Its physical and economic performance is well analyzed (e.g. Forster et al., 2007; Johansson et al., 2006; O'Neill, 2003), including its physical uncertainties related to atmospheric sinks (Reisinger et al., 2010; Manning and Reisinger, 2011). The original version of the GWP (henceforth: GWP(r)) (Lashof and Ahuja, 1990), in contrast, discounts the impacts and considers an average forcing value over possible future ranges in concentration ($C_{ref} = C_{ref}(\emptyset \text{ future})$) to account for the non-linearities in the concentration-forcing relation. The economic global warming potential (EGWP) (Wallis, 1994), a formally extended form of the GWP, additionally covers the rate of change of atmospheric forcing. In its two variants, it uses either the θ -function or discounting for inter-temporal aggregation. The Temperature Proxy Index TEMP (Tanaka et al., 2009; Shine, 2009) offers a slightly different perspective: it describes the optimal gas-dependent time horizon H for the GWP(H) as a result of a tuning process with respect to historical RF and temperature development. The Forcing Equivalent Index (FEI) (Manning and Reisinger, 2011; Wigley, 1998), a similar approach, was also designed to reproduce a historical pathway of RF.

3.2.2 Global Cost Potential

The GDP is grounded in the cost-benefit analysis, building on marginal climate change impacts and marginal costs of emission reductions. In view of the large uncertainty associated with economic evaluation of climate impacts, and the possible existence of discontinuous changes in the earth's climate system (or "Tipping Points", cf. Lenton et al., 2008), the cost-effectiveness framework is proposed as an alternative to the cost-benefit approach (Markandya et al., 2001): "guardrails" or "tolerable windows" for one or several climate variables such as ΔT or the rate of temperature change are adopted as boundary conditions for climate mitigation strategies (Petschel-Held et al., 1999; Bruckner et al., 1999). A prominent example of the cost-effectiveness approach is the objective to avoid dangerous anthropogenic interference with the climate system by keeping global warming below 2°C, a target which is widely accepted in the international climate policy community (Copenhagen Accord) (e.g. Meinshausen et al., 2009). Also, the vast majority of climate change mitigation scenarios are based on a cost-effectiveness approach (Fisher et al., 2007).

Analytically, cost-effectiveness approaches can be treated as special cases of the cost-benefit analysis in which the damage cost curve (D) is implicitly assumed to be zero within the “tolerable window” and to diverge to infinity at a physical impact threshold PI_{thres} (θ_∞ -function) :

$$D(PI) = \theta_\infty(PI - PI_{thres}) = \begin{cases} 0 & \text{for } PI < PI_{thres} \\ \infty & \text{for } PI \geq PI_{thres} \end{cases} \quad (7)$$

In the hypothetical case of CO_2 as the only greenhouse gas, the optimal carbon price would emerge as MAC at the pre-defined climate threshold.

While cost-effectiveness approaches are primarily designed for the derivation of global emission targets, they have peculiar implications for the derivation of metrics, which are an inherently marginal concept. In cost-effectiveness approaches, marginal damages are implicitly assumed to be zero below the climate target and infinitely large at the threshold. While Eq.(4) (Section 3.1) cannot be evaluated in this case, one can take advantage of the condition that for cost-optimal climate policy, the metric also has to be equal to the ratio of MAC s. This gives rise to the Global Cost Potential (GCP) (Kandlikar, 1996; Tol et al., 2008; Johansson, 2011), also referred to as “price ratios” (Manne and Richels, 2001):

$$M_i^{CE} = MAC_i^{PI_{thres}} / MAC_{CO_2}^{PI_{thres}} \quad (8)$$

The GCP is given by the ratio of two gases’ MAC s least cost emission trajectory maintaining a prescribed climate target. Typically, the physical impact threshold PI_{thres} is either expressed in terms of ΔT (e.g. Manne and Richels, 2001) or RF (e.g. Van Vuuren et al., 2006).

3.3 Synthesis

Using our conceptual framework, the prevalent metrics can be categorized unambiguously according to their choice of impact and weighting function (Table 1). The impact proxy is the most pivotal element of a metric and therefore serves as a primary classification criterion. The GDP considers economic damage as impact proxy which is in general a non-linear function of the physical state of the climate and subject to substantial uncertainty (Fig. 1a). As elaborated in Section 3.2.1 and illustrated in Fig. 1a, purely physical climate metrics take a simplifying approach by (using physical climate parameters as an impact proxy, thus) implicitly assuming a linear relationship between economic damage and physical impact proxy ΔT (GTP_p , $MGTP$, $TEMP$), RF ($GWP(r)$, $GWP(H)$, FEI), or RF and the change of RF ($EGWP$). An alternative group of metrics is based on cost-effectiveness approaches, thus implicitly assuming damages to be zero below a certain temperature ($GCP(\Delta T)$) or forcing threshold ($GCP(RF)$), cf. Section 3.2.2 and Fig. 1a.

The second important dimension in metric design is the choice of temporal weighting function (Fig. 1b). All physico-economic metrics and some physical metrics use exponential discounting for aggregating impacts over time. Alternative approaches are unit step functions ($GWP(H)$, $MGTP$, $TEMP$, FEI) or end-point weighting (GTP_p , $GTP_p(t)$).

As in the GCP metrics, the GTP_p is based on the cost-effectiveness rationale. In fact, the $GTP_p(t)$ was designed to provide an easy-to-calculate alternative to the GCP and indeed yields similar metric values (Shine et al., 2007). This can be understood from the fact that both approaches only consider the long-term effect of emissions, either by explicitly assuming a temporal weighting function that excludes the short and medium time-scales (as in the case of the GTP_p), or by assuming an impact function that is non-zero only in the distant future (as in the case of the GCP). In more formal terms, it can be shown that the GTP is a special case of the GCP if abatement costs in different periods can be assumed to be independent (Tol et al., 2008). The cost-effective temperature potential (CETP), which by construction of its temporal weighting function only considers climate impacts that occur after the climate target has been reached, is a physical metric that can almost exactly reproduce the behavior of the GCP (Johansson, 2011).

The conceptual framework illustrates the interrelations between different metrics (Fig. 2). It shows that alternative metrics can be constructed as variants of the GDP. For all metrics, normative judgements are involved in the choice of the time frame parameter, be it the discount rate r in the context of exponential discounting, the time horizon H in unit step aggregation or the end-point t_x . In the case of the physico-economic metrics, further normative assumptions are relevant in the derivation of the damage function or the choice of the climate target PI_{thres} .

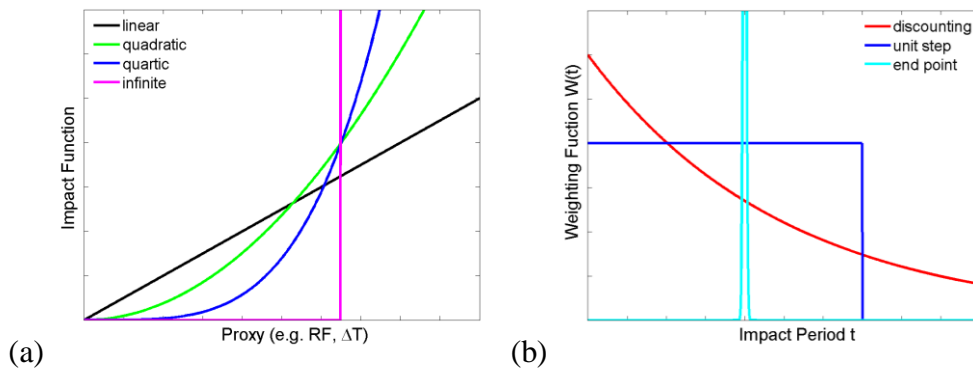

Figure 1: *Schematic representation of commonly used (a) impact functions and (b) temporal weighting functions. All physical metrics assessed in this study use linear impact functions, while impact functions considered for the GDP typically include non-linear convex functions. The GCP implicitly considers zero impacts below the climate threshold and infinite impacts above. Physico-economic metrics typically use exponential discounting for the temporal weighting function, while unit-step and end-point weighting is more commonly used in physical metrics.*

Table 1: Classification of climate metrics. I specifies the selected climate impact proxy including the underlying damage function and \bar{C}_{ref} (scenario (scen), constant (const), specifications see text). W is characterized by the type of weighting function and the relevant time frame parameter r , H or t_x , respectively (specification see text).

Impact function I		Weighting function W		
Implicit Damage function	Atmospheric background C_{ref} , specification	Discounting discount rate r	constant (θ – function) time horizon H	End point (δ – function) end point t_x
D $D = f(\Delta T)$	scen, exogenous	GDP		
ΔT $D = \theta_\infty(\Delta T - \Delta T_{thres})$	scen, endogenous	GCP(T)		
$D \propto \Delta T$	const, ref(t_0)		MGTP	
$D \propto \Delta T$	const, ref(t_0)			GTP
$D \propto \Delta T$	scen, historical		TEMP	
ΔRF $D = \theta_\infty(RF - RF_{thres})$	scen, endogenous	GCP(RF)		
$D \propto RF$	scen, ref(\emptyset future)	GWP(r)		
$D \propto RF$	const, ref(t_0)		GWP(H)	
$D = \gamma \cdot RF + \omega \cdot \partial RF / \partial t$	const, ref(t_0)	EGWP		
$D \propto RF$	scen, historical		FEI	

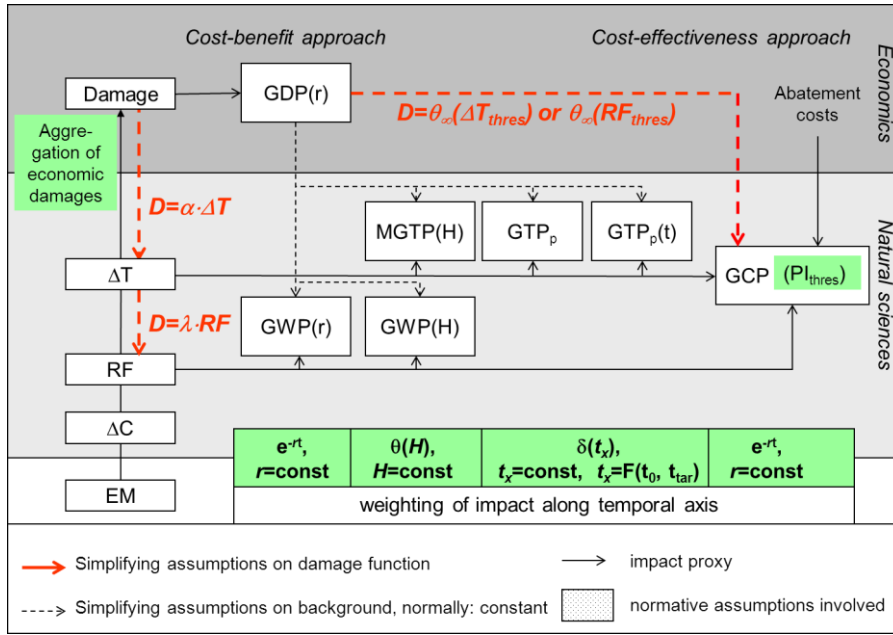

Figure 2: Interrelation between the GDP and selected physical and physico-economic metric approaches (GWP, MGTP, GTP_p , $GTP_p(t)$ and GCP) highlighting the underlying policy objective, impact proxy, weighting function and respective scientific discipline.

4 Discussion and conclusion

Our conceptual framework illustrates that metric approaches can be classified unambiguously according to their implicit assumptions about the impact and temporal weighting function. For a metric to be optimal from an economic point of view, it must be based on the evaluation of marginal economic costs incurred by emissions. The GDP follows this basic rationale, and thus would ensure – absent uncertainty – multi-gas abatement strategies to be cost-optimal for a given set of normative assumptions.

As shown in Section 3.3, the vast majority of metrics used in the literature can be constructed as variants of the GDP. Also the guardrail approach used in a cost-effectiveness framework can be seen as special case of the GDP in which damages are assumed to grow to infinity at a particular climate threshold. Given (a) its property of economic efficiency, and (b) its flexible formulation of the damage function, which allows establishing all other metrics as variants of it, the GDP is uniquely positioned and can be used as a reference point for the evaluation of metrics.

The paramount challenge in the design of metrics is to deal with uncertainty. Following Dorbian et al. (2011), and with partly different definitions than in Plattner et al. (2009), we distinguish between the following types of uncertainties:

- *value-based uncertainty*, the degree to which normative judgements are involved,

- *scientific uncertainty*, uncertainty in the knowledge about the underlying processes in the causal chain between emissions and impact function,
- *scenario uncertainty*, the degree to which the metric depends on the future states of the world, e.g. atmospheric background conditions, and
- *structural uncertainty*, the degree to which the metric represents the policy-relevant real world trade-offs.

While the first three types of uncertainties are of explicit nature with a direct link to operational feasibility, the latter takes effect implicitly. The choice of metric is largely characterized by trade-offs between different kinds of uncertainties. This can be illustrated by comparing the GWP and GDP metrics. The key advantage of the GWP(H) lies in the fact that (a) the value-based uncertainty is reduced to the choice of time horizon, (b) the scientific uncertainty is kept to a manageable level by only considering the causal chain between emissions and forcing, and (c) the scenario uncertainty is eliminated by assuming constant background conditions. On the other hand, the GWP is characterized by rather high implicit structural uncertainty and low policy relevance, since there is no direct link between RF and climate damages, and likewise, future atmospheric background conditions will not remain constant.

In this respect, the GDP is distinctly different from the physical metrics. As elaborated above, it ensures economic efficiency, thus it accurately represents real-world trade-offs and features low implicit structural uncertainty. This comes, however, at the expense of more explicit uncertainty: (a) high value-based uncertainty as, in addition to the choice of discount rate, normative judgements are involved in the valuation and aggregation of damages, (b) higher scientific uncertainty as the entire causal chain from emissions to damages is represented, and (c) scenario uncertainty as we are unsure about the future state of the world.

Table 2 provides an indicative overview of how metrics perform in terms of different uncertainty categories. It further demonstrates numerically some explicit uncertainties, using the example of CO₂ equivalences for methane. Generally speaking, physico-economic metrics are characterized by lower structural uncertainty which in principle makes them most policy relevant and more flexible to adjust to our knowledge of climate change and its impacts. This feature comes at the expense of higher scientific, value-based and scenario uncertainties (wider range of possible metric values). Physical metrics, in contrast, have high structural but lower value-based, scientific and scenario uncertainties (smaller range of possible metric values).

Table 2: Commonly used metric approaches: Indicative and qualitative assessment of different kinds of uncertainties (uncertainty increases with number of bullet points). Exemplary CO₂ equivalences for methane illustrate the range of possible values.

Metric	explicit uncertainties			implicit uncertainties	CO ₂ eq. for CH ₄ (Examples) ¹	
	scientific	value-based	scenario	structural	median ²	uncertainty range ³ (standard)
GWP	•	••	•	•••••	27.2	22.5 - 32.5 (2.8)
GTP	••	••	••	••••	6.2	4.5 - 9.0 (1.8)
GCP (RF)	••	•••	••	•••		
GCP (T)	•••	•••	••	••		
GDP	•••	••••	••	•	26.3	15.0 - 40.0 (6.7)
	<i>Increasing operationalizability with decreasing uncertainty</i>			<i>Increasing policy relevance with decreasing uncertainty</i>	¹ Boucher et al. (2012); ² 100-yr GWP, 100-yr GTP _p and GDP, include the conversion of CH ₄ into CO ₂ ; ³ 90% confidence interval	
	Implications for policy applications					

While economic efficiency and environmental effectiveness are the most crucial evaluation criteria, it is important to note that for any practical policy application, simplicity and transparency are also important (Fuglestedt et al., 2003 and 2010; Wuebbles et al., 2010). So far, the GWP, simple and transparent and thus easy to operationalize, has been the metric of choice for policy applications. In this metric, many of the relevant uncertainties are concealed by simplifying structural assumptions. While physico-economic metrics such as the GDP are much more difficult to operationalize, it can be seen as their advantage that they make the relevant uncertainties explicit. As an alternative approach to the use of simplifying physical metrics, policymakers could consider a GDP-based approach, in which the relevant value judgements and assumptions are considered in a direct and transparent manner, see e.g. Hammitt et al. (1996), Dorbian et al. (2011) and Boucher (2012).

Particularly with regard to the interdisciplinary retrieval of climate metrics stipulated in the scientific literature (e.g. Shine, 2009) and on the level of the IPCC (Plattner et al., 2009), the conceptual framework provides a valuable basis for discussions, since it allows scientists and policymakers to disentangle and compare relevant implicit and explicit assumptions in a transparent way. As the framework elucidates the relationship between physical metrics and more comprehensive metrics that include the economy, it may help to enhance the scientific discourse between researchers from different climate research communities.

Acknowledgements

This paper is part of the PhD thesis of Odette Deuber which has been funded by the Heinrich Böll Stiftung. We are grateful to Prof. Robert Sausen (Deutsches Zentrum für Luft- und Raumfahrt) and Jan Minx (TSU IPCC WG3) for helpful discussions.

5 References

- Baumol, W.J., 1972. On Taxation and the Control of Externalities. *Am. Econ. Rev.* 62, 307-322.
- Berntsen, T.M., Tanaka, K. and Fuglestvedt, J.S., 2010. Does black carbon abatement hamper CO₂ abatement? *Clim. Change Lett.* 103, 627-633.
- Boas, M.L., 2006. *Mathematical Methods in the Physical Sciences*, 3rd edition. John Wiley & Sons Inc. United States of America. <http://www.philadelphia.edu.jo/math/syllabi/250473.pdf>.
- Bruckner, T., Petschel-Held, G., Tóth, F.L., Füssel, H.M., Helm, C., Leimbach, M. and Schellnhuber H.J., 1999. Climate change decision-support and the tolerable window approach. *Environ. Model. Assess.* 4, 217-234.
- Dorbian, C.S., Wolfe, P.J., Waitz, I.A., 2011. Estimating the climate and air quality benefits of aviation fuel and emission reductions. *Atmos. Environ.* 45, 2750-2759.
- Eckhaus, R.S., 1992. Comparing the Effects of Greenhouse Gas Emissions on Global Warming. *Energy J.* 13, 25-35.
- Deuber, O., Matthes, S., Sausen, R., Ponater, M., Lim, L., 2012. A physical metric-based framework for evaluating the climate trade-off between CO₂ and contrails: the case of lowering aircraft flight trajectories. *Environ. Sci. Pol.* (submitted).
- Fankhauser, S., 1995. *Valuing Climate Change: The Economics of the Greenhouse*. Earthscan, London.
- Fisher, B.S., Nakicenovic, N., Alfsen, K., Corfee Morlot, J., de la Chesnaye, F., Hourcade, J.Ch., Jiang, K., Kainuma, M., La Rovere, E., Matysek, A., Rana, A., Riahi, K., Richels, R., Rose, S., van Vuuren, D. and Warren, R., 2007. Issues related to mitigation in the long term context. In: Metz, B., Davidson, O.R., Bosch, P.R., Dave, R., Meyer, L.A. (Eds.), *Climate Change 2007: Mitigation. Contribution of Working Group III to the Fourth Assessment Report of the IPCC*. Cambridge University Press, Cambridge, pp. 169-250.
- Forster, P., Ramaswamy, V., Artaxo, P., Berntsen, T., Betts, R., Fahey, D.W., Haywood, J., Lean, J., Lowe, D.C., Myhre, G., Nganga, J., Prinn, R., Raga, G., Schulz, M., Van Dorland, R., 2007. Changes in Atmospheric Constituents and in Radiative Forcing, in: Solomon, S., Qin, Q., Manning M., et al. (Eds.), *Climate Change 2007: The Physical Science Basis. Contribution of Working Group I to the Fourth Assessment Report of the Intergovernmental Panel on Climate Change*. Cambridge University Press, Cambridge, United Kingdom and New York, NY, USA. pp. 129-234.
- Fuglestvedt, J.S., Berntsen, T.K., Godal, O., Sausen, R., Shine, K.P. and Skodvin, T., 2003. Metrics of climate change: Assessing Radiative Forcing and Emission Indices. *Clim. Change* 58, 267-331.

- Fuglestad, J.S., Shine, K.P., Berntsen, T., Cook, J., Lee, D.S., Stenke, A., Skeie, R.B., Velders, G.J.M., Waitz, I.A., 2010. Transport impacts on atmosphere and climate: Metrics. *Atmos. Environ.* 44, 4648-4677.
- Gillett N.P., Matthews H.D., 2010. Accounting for carbon cycle feedbacks in a comparison of the global warming effects of greenhouse gases. *Environ. Res. Lett.* 5 034011, 1-6.
- Godal, O., 2003. The IPCC's assessment of multidisciplinary issues: the case of greenhouse gas indices. *Clim. Change* 58, 243-249.
- Hammitt, J.K.H., 1999. Evaluation endpoints and climate policy: Atmospheric stabilization, benefit-cost analysis, and near-term greenhouse-gas emissions. *Clim. Change* 41, 447-468.
- Hammitt, J.K.H., Jain, A.K., Adams, J.L. and Wuebbles, D.J., 1996. A welfare-based index for assessing environmental effects of greenhouse-gas emissions. *Nature* 381, 301-303.
- Hanemann, M., 2010. The Impact of Climate Change: An Economic Perspective. In: Cerdá, E., Labandeira, X. (Eds.) *Climate Change Policies: Global Challenges and Future Prospects*. Edward Elgar, Cheltenham UK, Northampton MA USA, pp. 9-28.
- IPCC, 1990. *Climate Change: the Intergovernmental Panel on Climate Change Scientific Assessment*. Cambridge University Press, Cambridge.
- Johansson, D.J.A., Persson, U.M. and Azar, C., 2006. The cost of using global warming potentials: Analysing the trade-off between CO₂, CH₄ and N₂O. *Clim. Change* 77, 291-309.
- Johansson, D.J.A., 2011. Economics- and physical-based metrics for comparing greenhouse gases. *Clim. Change* 110, 123-141.
- Kandlikar, M., 1995. The relative role of trade gas emissions in greenhouse abatement policies. *Energy Policy* 23, 879-883.
- Kandlikar, M., 1996. Indices for comparing greenhouse gas emissions: integrating science and economics. *Energy Econ.* 18, 265-281.
- Lashof, D.A. and Ahuja, D.R., 1990. Relative contributions of greenhouse gas emissions to global warming. *Nature* 344, 529-531.
- Lenton, T.M., Held, H., Kriegler, E., Hall, J.W., Lucht, W., Rahmstorf, S. and Schellnhuber, J., 2008. Tipping elements in the Earth's climate system. *Proc. Natl. Acad. Sci.* 105, 1786-1793.
- Manne, A.S. and Richels, R.G., 2001. An alternative approach to establishing trade-offs among greenhouse gases. *Nature* 410, 675-677.
- Manning, M. and Reisinger, A., 2011. Broader perspective for comparing different greenhouse gases. *Philos. Trans. R. Soc. London A* 369, 1891-1905.

- Markandya, A., Halsnæs, K., Lanza, A., Matsuoka, Y., Maya, S., Pan, J., Shogren, J., de Motta, R.S. and Zhang, T., 2001. Costing methodologies. In: Metz, B., Davidson, O., Swart, R. and Pan, J. (eds.) *Climate change 2001: Mitigation. Contribution of Working Group III to the Third Assessment Report of the Intergovernmental Panel on Climate Change*. Cambridge University Press, Cambridge, pp. 451-498.
- Meinshausen, M., Meinshausen, N., Hare, W., Raper, S.C.B., Frieler, K., Knutti, R., Frame, D.J. and Allen, M.R., 2009. Greenhouse-gas emission targets for limiting global warming to 2°C. *Nature* 458, 1158-1163.
- Nordhaus, W.D., 1991. To slow or not to slow: the economics of the greenhouse effect. *Econ. J.* 101, 920-937.
- Nordhaus, W.D. and Boyer, J., 2000. *Warming the world: economic models of global warming*, MIT Press, Cambridge, USA.
- O'Neill, B.C., 2000. The Jury is still out on Global Warming Potentials, *Clim.Change* 44, 427-443.
- O'Neill, B.C., 2003. Economics, natural science and the costs of global warming potentials. An Editorial Comment. *Clim. Change* 58, 251-260.
- Peters, G.P., Aamaas, B., Berntsen, T., Fuglestvedt, J.S., 2011. The integrated global temperature change potential (iGTP) and relationships between emission metrics. *Environ. Res. Lett.* 6, 044021.
- Petschel-Held, G., Schnellhuber, H.J., Bruckner, T., Tóth, F.L. and Hasselmann, K., 1999. The Tolerable Windows approach: theoretical and methodological foundations. *Clim. Change* 41, 303-331.
- Pigou, A.C., 1932. *The Economics of Welfare*, Macmillan, London.
- Plattner, G.K., Stocker, T., Midgley, P. and Tignor, M., 2009. IPCC Expert Meeting on the Science of Alternative Metrics: Meeting Report. 1-75. <http://www.ipcc.ch/pdf/supporting-material/expert-meeting-metrics-oslo.pdf>.
- Reilly, J.M. and Richards, K.R., 1993. Climate change damage and the trace gas index issue. *Environ. Resour. Econ.* 3, 41-61.
- Reisinger, A., Meinshausen, M., Manning, M., Bodeker, G., 2010. Uncertainties of global warming metrics: CO₂ and CH₄. *Geophys. Res. Lett.* 7, L14707.
- Schmalensee, R., 1993. Comparing Greenhouse Gases for Policy Purposes. *Energy J.* 14, 245-55.
- Shine, K.P., Fuglestvedt, J.S., Hailemariam, K., Stuber, N., 2005. Alternatives to the global warming potential for comparing climate impacts of emissions of greenhouse gases. *Clim. Change* 68, 281-302.
- Shine, K.P., Berntsen, T.K., Fuglestvedt, J.S., Skeie, R.B., Stuber, N., 2007. Comparing the climate effect of emissions of short- and long-lived climate agents. *Philos. Trans. R. Soc. London A* 365, 1903-1914.

- Shine, K.P., 2009. The global warming potential – the need for an interdisciplinary re-trial. An editorial comment. *Clim. Change* 96, 467-472.
- Smith, S.J., 2003. The evaluation of greenhouse gas indices. An editorial comment. *Clim. Change* 58, 261-265.
- Stern, N., 2007. *The Economics of Climate Change. The Stern Review*, Cambridge University Press, New York.
- Tanaka, K., O'Neill, B.C., Rokityanskiy, D., Obersteiner, M. and Tol, R.S.J., 2009. Evaluating Global Warming Potentials with historical temperature. *Clim. Change* 96, 443-466.
- Tietenberg, T., 1992. *Environmental and resource economics*, 3rd ed. HarperCollins, New York.
- Tol, R.S.J., 1999. The Marginal Costs of Greenhouse Gas Emissions. *Energy J.* 20, 61-81.
- Tol, R.S.J., 2003. Is the uncertainty about climate change too large for expected cost-benefit analysis. *Clim. Change* 56, 265-289.
- Tol, R.S.J., 2005. The marginal damage costs of carbon dioxide emissions: an assessment of the uncertainties. *Energy Pol.* 33, 2064-2074.
- Tol, R.S.J., Berntsen, T.K., O'Neill, B.C., Fuglestvedt, J.S., Shine, K.P., Balkanski, Y., and Makra, L., 2008. Metrics for Aggregating the Climate Effect of Different Emissions: A Unifying Framework. *ESRI Working Paper 257*, 1-16.
- Van Vuuren, D.P., Weyant, J. and de la Chesnaye, F., 2006. Multi-gas scenarios to stabilize radiative forcing. *Energy Econ.* 28, 102-120.
- Wallis, M.K. and Lucas, N.J.D., 1994. Economic Global Warming Potentials. *Intern. J. Energy Res.* 18, 57-62.
- Wigley, T.M.L., 1998. The Kyoto Protocol: CO₂, CH₄ and climate implications. *Geophys. Res. Lett.* 25, 2285-2288.
- Wuebbles, D., Forster, P., Rogers, H., and Herman, R., 2010. Issues and uncertainties affecting metrics for aviation impacts on climate. *Bull. Am. Meteorol. Soc.* 91, 461-463.